

SPE BULLET RESISTING | PACKAGE PASSER

FEATURES

- ▶ Welded prime painted steel walls & doors
- ▶ Adjustable flange allows installation in walls up to 12" thick
- ▶ Interlock mechanism allows only one door to be opened at a time
- ▶ Wide range of sizes available
- ▶ Delivered assembled and ready for installation
- ▶ Inside paddle latch for extra security (optional)

PRODUCT DESCRIPTION

The SPE package passer consists of a rectangular steel box with prime painted steel doors. A mechanical interlocking mechanism prevents both doors from being opened simultaneously, allowing packages to be passed through a barrier without a breach of security. The SPE is designed to pass small to medium sized packages on a moderate to frequent basis, with a long service life and little or no maintenance.

AVAILABLE SIZES

Typical Standard Size:

Box OD 18" W x 18" H x 18" D

Custom sizes manufactured based on maximum package dimensions. Consult factory for unit sizing. Please contact our sales/engineering department for current pricing & delivery information.

BALLISTIC OPTIONS

Bullet Resistant Level 1

Bullet Resistant Level 2

Bullet Resistant Level 3

SPECIFICATIONS

A. CONSTRUCTION

1. Wall mounted package exchange system constructed of steel and stainless steel. All welded construction.
2. Outer and inner doors have an interlocking mechanism that permits only one door to be in the open position.
3. Paddle latch has key lock (Exterior Door) with brushed chrome finish.
4. Wirepull handle on interior door.
5. Exchanger designed to accommodate variable wall thickness up to 12" thick
6. Finishes available - Prime painted, or stainless steel throughout.

B. OPTIONAL FEATURES

1. Stainless steel exterior door
2. Interior paddle latch

MARKETS SERVED

- ▶ Financial Institutions
- ▶ Convenience Store
- ▶ Pharmacies
- ▶ Law Enforcement Facilities
- ▶ Other "at risk" facilities

HANDLING INFORMATION

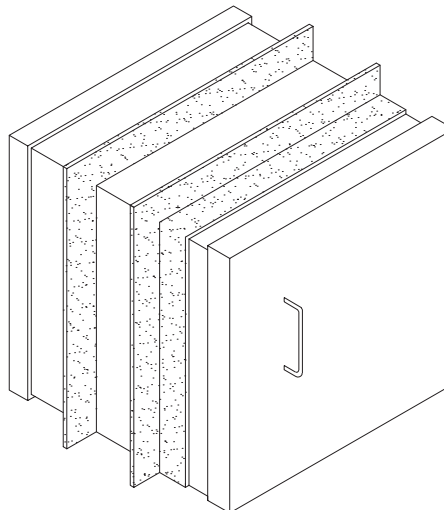

Handling: Care should be exercised during shipping and handling to maintain package passer appearance.

Storage: Store upright in a dry, well ventilated building or shelter at a constant temperature. Do not store in damp areas or freshly plastered buildings. Place unit on wood blocks at least 2" high to prevent moisture damage.

Application: Remove from protective container just prior to installation. Care should be exercised when installing window to insure that installation is level, plumb, square and secure.

Cleaning: You must clean the package passer during and after the construction period to maintain optimum performance and aesthetic properties. To clean, use a soft, clean cloth and a mild soap, detergent, or slightly acidic cleaning solution (such as vinegar). Wipe with a clean, lint-free cloth.

TECHNICAL SUPPORT

TSS maintains a full staff of professional and experienced sales representatives, project estimators, engineers, draftsmen, craftsmen and installers ready to assist in all phases of the bullet resistant project from initial design through installation. Consult our sales department or your local representative for assistance with all your bullet-resistant needs at 1.517.223.7807.

LIMITED WARRANTY

TSS offers a twelve month limited warranty. This warranty does not cover damage caused by neglect, abuse, vandalism, improper maintenance, accident or any other cause beyond the suppliers control not arising out of defects in material or workmanship. The warranties stated replace and exclude all other warranties. The warranty is limited to replacing products that fail to meet specification, or are defective in quality or workmanship at the time of delivery. TSS will not be responsible for (re)installation expenses or any direct or indirect loss(es) which may result from a defective product. TSS reserves the right to field inspect any product alleged to be defective. The buyer is responsible for any consequences resulting from product use.

