

GLAZING OPTIONS

- 1 1/4" Uncoated Acrylic
- 3/4" GCP 750
- 3/4" LP 750 Laminated Polycarbonate Acrylic
- 1 3/8" Uncoated Acrylic
- 1" TSS 002 L/S
- 1" LP 1000 Laminated
- 1 1/4" LP 1250 Laminated
- 1 1/4" TSS 003 L/S

ANODIZING FINISH OPTIONS

- Clear Anodizing
- Dark Bronze Anodizing

Other custom coating options are available upon inquiry

PROPERTIES & SPECIFICATIONS

Protection	9mm .357 Mag .44 Mag
Ballistic Data	Max Velocity 1: ≤1350 ft/s Max Velocity 2: ≤1485 ft/s
Yield Strength	40,000 PSI
Ultimate Tensile Strength	45,000 PSI
Brinell Hardness	95
Rockwell Hardness	B60
Density	0.098 lbs. /cu. in.
Spec. Gravity	2.7
Melting Point	1090° F
Modulus of Elasticity Tension	10
Modulus of Elasticity Torsion	3.8

BALLISTIC RATING

- U.L. 752 Level 1 – 9 mm
- U.L. 752 Level 2 – .357 Mag
- U.L. 752 Level 3 – .44 Mag

LIMITED WARRANTY

12-month limited warranty. Does not cover damage from neglect, abuse, vandalism, improper maintenance, or any other cause not arising out of defects in material or workmanship. The warranties stated replace and exclude all other warranties. The warranty is limited to replacing products that fail to meet specification, defective in quality, or workmanship at time of delivery. TSS is not responsible for (re)installation expenses or any direct or indirect loss or losses which may result from a defective product. TSS reserves the right to field inspect any product alleged to be defective. Buyer is responsible for any consequences from the product use.

2 PIECE CHANNEL & FRAMING

PRODUCT: TSS B.L. 2.5

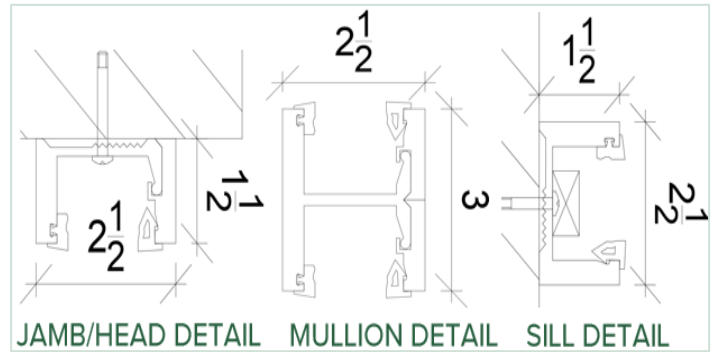

STANDARDS

- ASTM B 209
- ASTM B 221

PREPARATION

Prior to installing the bullet resistive material, the contractor shall verify that all supports have been installed as required by the contract documents and architectural drawings, and approved shop/CAD drawings, if required. Installer shall notify architect of any unsatisfactory preparation that is responsibility of another installer. Clean and prepare all surfaces per manufacturer's recommendations for achieving the best results for the substrate under the project conditions.

INSTALLATION

Do not begin installation until openings have been verified and surfaces properly prepared in accordance with Drawings. Install in accordance with manufacturer's instructions and UL 752. Set all equipment plumb. TSS Bullet Resistant Storefronts Install in accordance with manufacturer's instructions.

Install plumb, level, square, true to line, and without warp or rack. Provide all fasteners required for installation. Anchor frames securely in place to supports. Use attachment methods permitting adjustment for construction tolerances, irregularities, alignment, and expansion and contraction. Separate aluminum from other metal surfaces with bituminous coatings or other means approved by Architect. Sheet Metal Flashing: Coordinate with sheet metal flashing as specified in Section 07620. Joint Sealants: Install joint sealants as specified in Section 07920.

POST APPLICATION

Inspection and Cleaning: Verify installation is complete and complies with manufacturer's requirements. Clean product and accessories, removing excess sealant, labels and protective covers. Product Warranty: Applicable warranty shall be issued to owner upon final release of completed project.

TOTAL SECURITY SOLUTIONS

P: 517.223.7807 | info@tssbulletproof.com | F. 517.223.0805 | 935 Garden Lane, Fowlerville, MI

Proprietary information not for public distribution